



National School Competition Framework Sport: Netball



National School Competition Framework Sport: Netball

Competition framework descriptor	Recommended competition	Level and location	Scheduling	Next steps in competition
<p>Key Stage 2: 7-9 years</p> <ul style="list-style-type: none"> Multi-skill festivals (termly) Theme based 	<ol style="list-style-type: none"> Multi-skills festivals with generic skills included in performance standards TOPS 2 active games 	<ul style="list-style-type: none"> Primary school clusters, flexible and moveable venues relevant to host schools and according to local need 	<ul style="list-style-type: none"> Each half-term to have a generic festival with different theme, e.g. throwing, running, jumping striking, etc 	<ul style="list-style-type: none"> Move to FUNdamentals of netball and employment of these skills in a game context
<p>Key Stage 2: 9-11 years</p> <ul style="list-style-type: none"> Multi-sport competition (six week block rotation) Central venue leagues Coaching and competition based on primary, secondary or club sites Menu of options available for flexibility of venue and competition 	<ul style="list-style-type: none"> High 5 (mini-game) Single sex or mixed Festival league competition at a moveable central venue Coaching and competition with emphasis on participation 	<ul style="list-style-type: none"> Primary school clusters at flexible venues May be held on secondary school site for any child or school (does not have to enter as part of school team) Does not have to enter each week Important that best boys who play in all teams are not sent to win for the school 	<ul style="list-style-type: none"> Three half-terms between September and April, with one held in an indoor venue 	<ul style="list-style-type: none"> Continue enjoying participating in fun leagues until reach secondary school
<p>Key Stage 3: 11-12 years</p> <ul style="list-style-type: none"> Multi-sport competition (monthly, three sports) E.g. central venue, leagues in a range of sports, coaching and competition at secondary, hub or club sites 	<p><u>Year 7</u></p> <ul style="list-style-type: none"> Level 1, 2 (see below) Level 1 is central venue, leagues, between September and March Year 7 should be moving to a seven-a-side game from the five-a-side mini-game so that coaching will encompass this 	<ul style="list-style-type: none"> Central venue although could be moved round the partner secondary schools 	<ul style="list-style-type: none"> Weekly, September – April (Calendar will be provided for levels and weeks!) 	<ul style="list-style-type: none"> Level 2 individuals representing the SSP against other SSPs in the county/area selected by teachers/coaches (if support required)

<p>Key Stage 3 and 4: 12-16 years</p> <ul style="list-style-type: none"> • Intra- and inter-school leagues and cup competitions within SSPs (year group teams) • Intra- and inter-school leagues • Teachers allow for maximum participation <p>Level 2</p> <ul style="list-style-type: none"> • Teachers/coaches attended Performance Standard Workshop (PSW) and Talent Development Workshop (TDW) are able to nominate to EN talent programmes • Teachers/coaches will select from SSP <p>Level 3</p> <ul style="list-style-type: none"> • <i>Managed programme for these players, with players' passport recording competition</i> • TASS/regional head coaches all attended TDW 2 to identify for EN talent programmes 	<ul style="list-style-type: none"> • Age groups will be according to SSP numbers, but may be either in single year groups, Year 8, 9, 10, 11, or combined year groups, Years 8 and 9, Years 10 and 11 <p>Level 1</p> <ul style="list-style-type: none"> • All pupils, all schools • All age groups, 11-16 years • After-school, Monday – Friday • Inter-school within SSP <p>Level 2</p> <ul style="list-style-type: none"> • Identified talented players from Level 1 only • Years 7-9 and Years 9-11 • After-school, Monday – Friday, possibly weekends where it does not clash with club leagues • Best athletes within SSPs in area • Intra-regional <p>Level 3 (<i>Not likely to happen until Year 2 or 3 of pilot</i>)</p> <ul style="list-style-type: none"> • Identified talented players from Level 2 only • Years 9-11 • Inter-regional within two area groups (e.g. North and South) • Two squads x ten from each region • Regional finals at Easter (nine x one squad) to link with club competition to include best athletes from both schools and clubs • (Possibly play on Franchise Super League days) 	<ul style="list-style-type: none"> • Central venue although could be moved round the partner secondary schools • Central venue although could be moved to different venues in the county • Use of indoor venue encouraged • Venues to be identified according to travel needs • Indoor venue encouraged for some use 	<ul style="list-style-type: none"> • Weekly, September – April • Monthly, October – March. Calendar to be provided so that Level 2 participants do not compete in Level 1 competitions • Monthly, November – March (not December) • Regional finals at Easter 	<ul style="list-style-type: none"> • Level 2 individuals representing the SSP against other SSPs in the area. Level 2 athletes may return to Level 1 competition when Level 2 not being played • Level 3 is identified talented players from the region in inter-regional competition within two area groups, e.g. North and South • Should be playing in clubs in regional leagues
--	--	---	---	--

<p>16-19 years</p> <ul style="list-style-type: none"> • <u>Not</u> for talented already identified as part of NGB talent programmes • ‘Junior Varsity’ to give this group an identity • Intra-mural competition within the learning community, e.g. schools, PE, sixth forms • Organised sport in core sports that match the secondary programmes • E.g. single venue festivals for a number of institutions during ring fenced time (Wednesday pm) 	<ul style="list-style-type: none"> a) Intra-school matches, and inter-school matches on a local basis, leading to a county festival b) Consolidated National U19 tournament for schools and clubs, across three/four rounds: district/borough, county, regional, national 	<ul style="list-style-type: none"> • Organised locally within area on a home and away basis 	<ul style="list-style-type: none"> • September – March 	
<p>Disability competition with priority of learning disability and/or deaf</p>	<ul style="list-style-type: none"> • All competition is according to availability of numbers • Age groups and types of competitions mirror framework • Disability may be inclusive or separate according to numbers and local need 	<ul style="list-style-type: none"> • Organised locally within SSP or across SSPs according to local need 	<ul style="list-style-type: none"> • As above framework 	

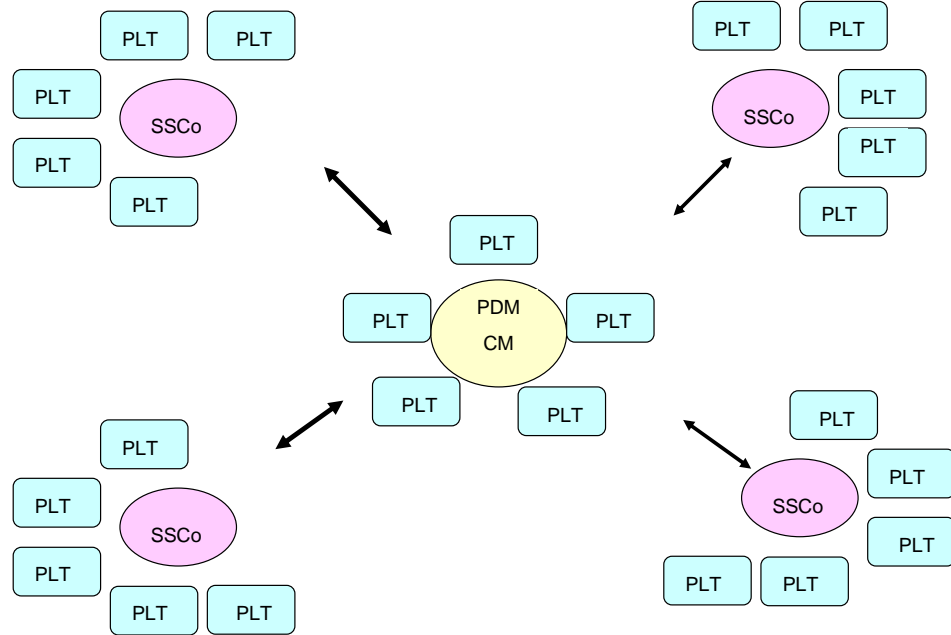

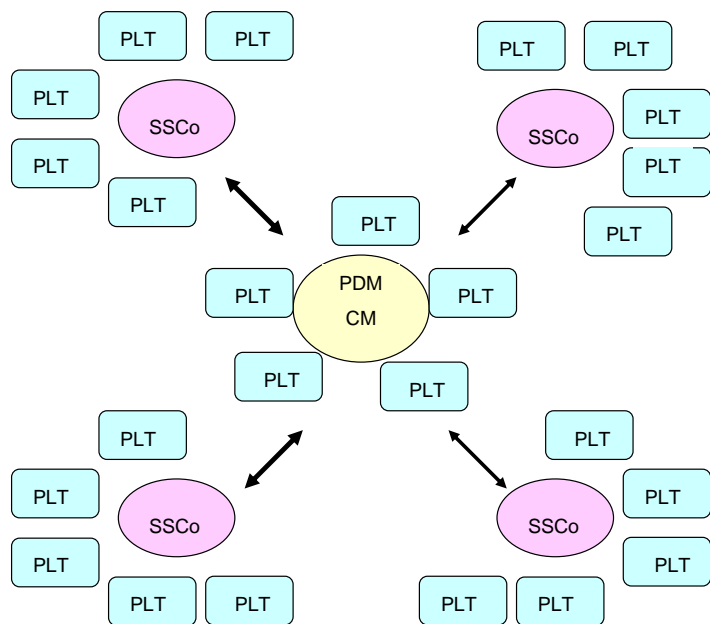

Netball has embedded the principles of Long Term Athlete Development in competitions for schools. The National Framework has two key objectives:

- greater opportunity to participate in quality competition
- competition for talented players/athletes.

School Sport Partnerships are key to enabling young players to achieve their potential within competition.

The young players with identified potential to develop, will access competition relevant to those individual needs.

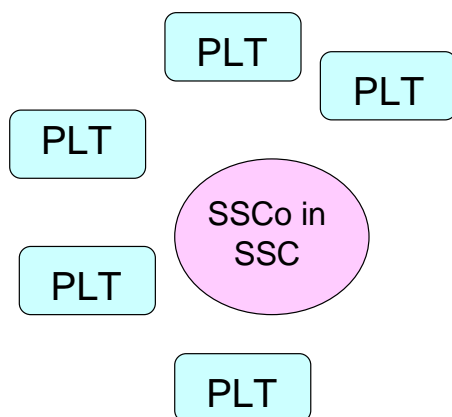

KEY STAGE 2: 7-9 YRS

- Multi-skills festivals (termly)
- Theme based with generic skills to achieve Performance standards
- Primary school clusters with flexible and moveable venues according to local need

SCHEDULE - TERMLY

KEY STAGE 2: 9-11 YRS

- Multisport
- H5 Netball, single sex or mixed
- Festival league competition at secondary school site (flexible)
- Coaching and competition with emphasis on participation
- Players do not have to enter as part of school team
- Important for all to participate not 'best boys' who play in all teams sent to win

SCHEDULE:- Half -termly between September and April with one held in an indoor venue. Festivals to be staffed by students in Secondary school having completed YNO, Jnr Umpire award or CSLA.

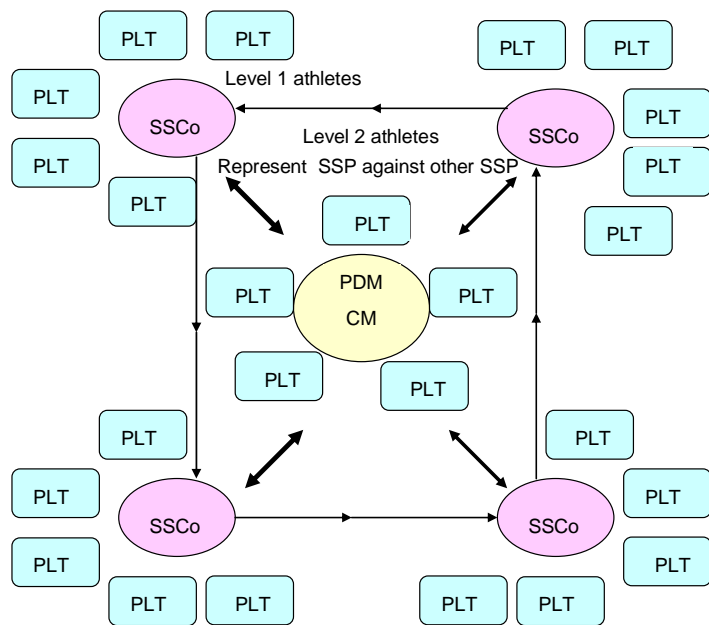

Level 3 athletes
Represent area SSPs in regional competition

Key Stage 3/4

Level 1
Participation for all players to enter, not just school team

Yr7, 8 + 9, 10 +11
Competitions within SSP

Level 2
Identified athletes to represent SSP against other SSPs in Area

Level 3
Identified athletes to represent Area SSPs in Regional Competition

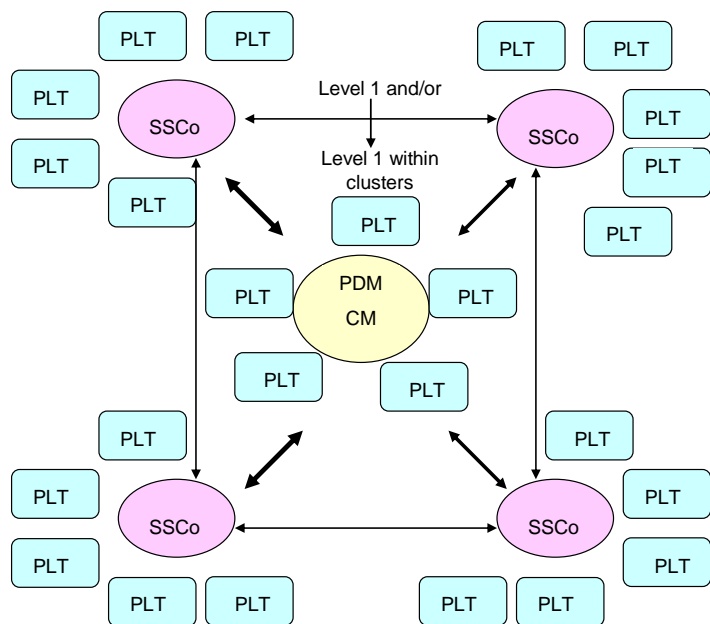

Level 2 representing SSP against other SSPs

Level 1: Participation

- Integration with Level 1 competition depending on disability or special school

or

- Separate learning disability festival competition

Level 2 for LD between schools in SSP

Level 3 is equivalent to previous Level 2, playing for SSP against other SSPs

England Netball Junior Competition

Club Competition

